

# GLOBO

## FAN

www.globo-lighting.com

03632B

03632W

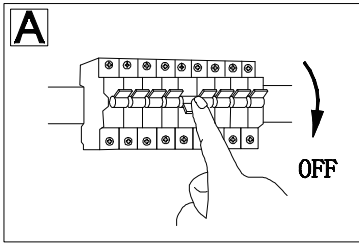

B

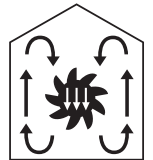
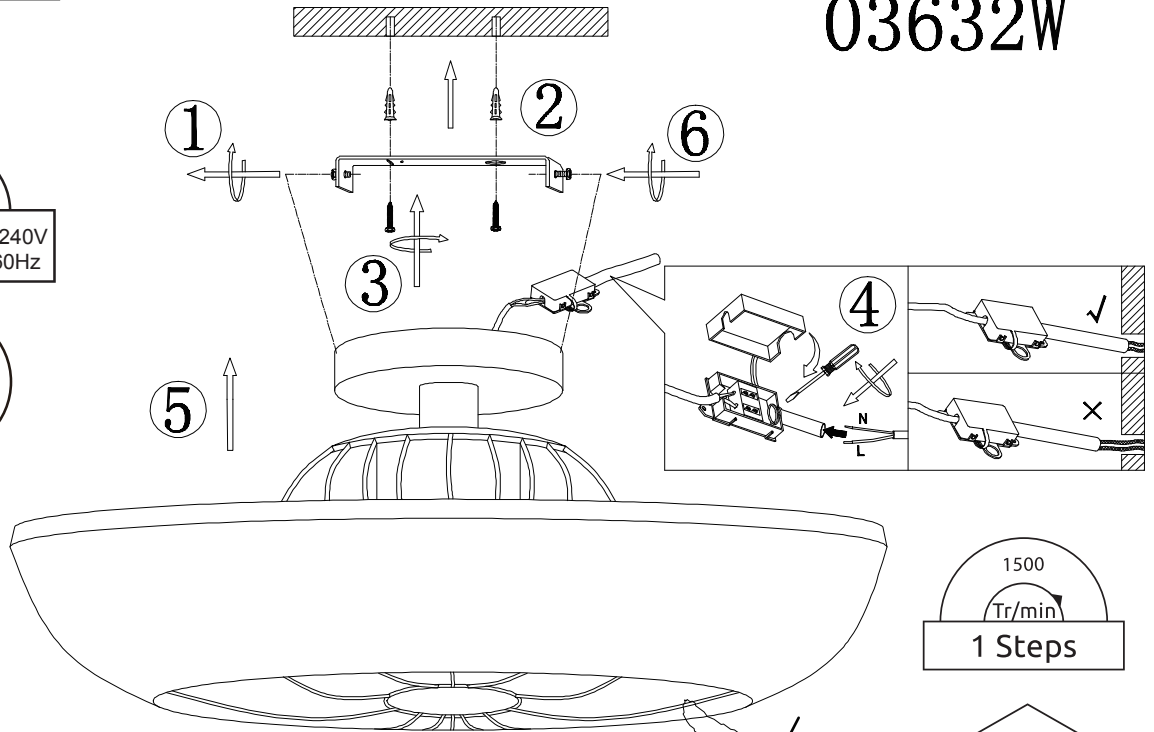

Step-1

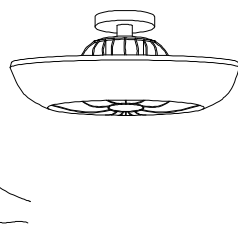
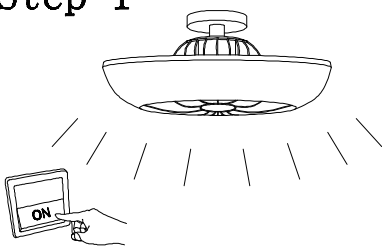

Step-2

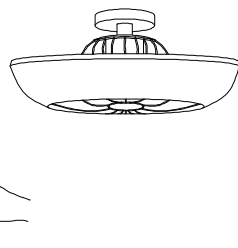
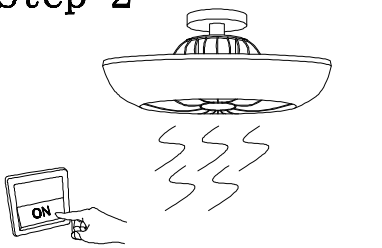

Step-3

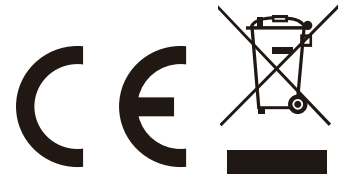
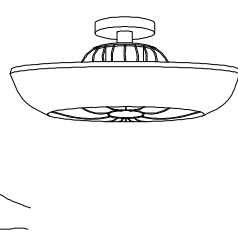
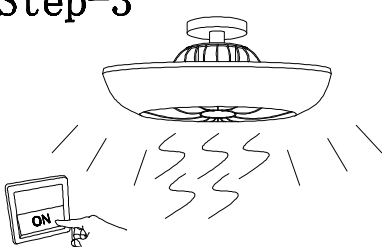

GLOBO Handels GmbH  
Gewerbestr. 3  
A-9184 Sankt Peter  
Austria

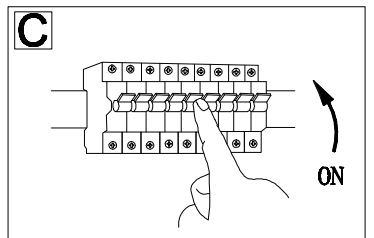

# Lichtquelle:

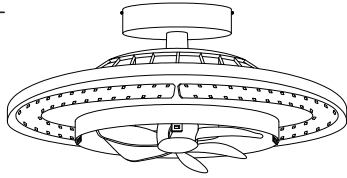

## DEU:

### Lichtquelle:

Die Lichtquelle ist nicht tauschbar, weil sie konstruktionsbedingt fest mit dem umgebenden Produkt verbunden ist.

Dieses Produkt enthält eine Lichtquelle der Energieeffizienzklasse <E>.



Betriebsgerät nicht austauschbar.



Leuchtmittel nicht austauschbar.

## GBR:

### Light source:

The light source is not interchangeable because it is determined by the surrounding product design.

This product contains a light source of energy efficiency class <E>.



Non replaceable control gear.



Non replaceable light source.

## BG:

### Източник на светлина:

Източникът на светлина не може да се подменя, тъй като поради конструкцията си е трайно фиксиран към заобикалящия го продукт. Този продукт включва светлинен източник с клас на енергийна ефективност <E>.



Управляващото устройство не може да се подменя.



Източникът на светлина не може да се подменя.

## BIH:

### Izvor svjetla :

Izvor svjetla nije zamjenjiv , jer je konstrukcijski pričvršćen na proizvod. Ovaj proizvod sadržava izvor svjetlosti klase energetske učinkovitosti <E>.



Pogonski uređaj se ne može zamjeniti



LED žarulje nije moguće zamjeniti

## CZ:

### Zdroj světla:

Světelný zdroj není možné vyměnit, protože je díky své konstrukci pevně spojený s produktem. Tento výrobek obsahuje světelný zdroj s třídou energetické účinnosti <E>.



Předřadník není vyměnitelný.



Světelný zdroj není vyměnitelný.

## DK:

### Lyskilde:

Lyskilden kan ikke udskiftes, fordi den er fast forbundet med det omgivende produkt. Dette produkt indeholder en lyskilde i energieffektivitetsklasse <E> .



Enheden kan ikke udskiftes.



Lyskilden kan ikke udskiftes.

## ET:

### Valgusallikas:

Valgusallikas ei ole välja vahetatav, sest ta on tootega ehituslikult kindlalt seotud. Toode sisaldab energiatõhususe klassi <E> valgusallikat.



Juhtimiseseadis ei ole välja vahetatav.



Lamp ei ole välja vahetatav.

## ES:

### Fuente de luz:

La fuente de luz no es sustituible porque está fija en el producto desde la construcción. Este producto contiene una fuente luminosa de la clase de eficiencia energética <E>.



Dispositivo de control no reemplazable.



Bombilla no reemplazable.

## FI:

### Valonlähde:

Valonlähde ei voi vaihtaa uuteen, sillä se on rakenteellisesti yhdistetty ympäröivään tuotteeseen.

Tämä tuote sisältää valonlähteen, jonka energiatehokkuusluokka on <E>.



Liitäntälaitetta ei voi vaihtaa.



Valonlähde ei voi vaihtaa.

## FR:

### Source lumineuse:

La source lumineuse n'est pas remplaçable car elle est, de par la construction du produit, liée de façon permanente à celui-ci.

Ce produit contient une source lumineuse de classe d'efficacité énergétique <E>.



Dispositif de commande non remplaçable.



Ampoule non remplaçable.

## GR:

### Φωτεινή πηγή:

Η φωτεινή πηγή δεν μπορεί να αντικατασταθεί, επειδή είναι για κατασκευαστικούς λόγους σταθερά συνδεδεμένη με το προϊόν που την περιβάλλει.

Το προϊόν αυτό περιέχει φωτεινή πηγή της τάξης ενεργειακής απόδοσης <E>.



Η διάταξη λειτουργίας δεν μπορεί να αντικατασταθεί.



Ο λαμπτήρας δεν μπορεί να αντικατασταθεί.

## HR:

### Izvor svjetla :

Izvor svjetla nije zamjenjiv , jer je konstrukcijski pričvršćen na proizvod . Ovaj proizvod sadržava izvor svjetlosti klase energetske učinkovitosti <E>.



Pogonski uređaj se ne može zamjeniti



LED žarulje nije moguće zamjeniti

## HU:

### Fényforrás:

A fényforrás nem cserélhető, mert felépítése miatt szilárdan csatlakozik a termékhez. Ez a termék egy <E> energiatékonysági osztályú fényforrást tartalmaz.



Az előtét nem cserélhető.



A fényforrás nem cserélhető

## IS:

### Ljósgrjafi:

Ljósgrjafinn er ekki útskiptanlegur vegna þess að hann er háður umliggjandi hönnun vörunnar. Varan inniheldur ljósgrjafa í orkuflökki <E>.



Ekki útskiptanlegur stýribúnaður.



Ekki útskiptanlegur ljósgrjafi.

## IT:

### Sorgente luminosa:

La sorgente luminosa non è intercambiabile perché è saldamente collegata al prodotto per via del suo design.

Questo prodotto contiene una sorgente luminosa di classe di efficienza energetica <E>.



Alimentatore non sostituibile.



Lampadine non intercambiabili.

## LT:

### Šviesos šaltinis:

Šis šviesos šaltinis yra nekeičiamas, nes jis prijungtas prie gaminio pagal jo konstrukciją. Šiame gaminyje yra šviesos šaltinis, kurio energijos vartojimo efektyvumo klasė <E>.



Valdymo įtaisas yra nekeičiamas.



Šviesos šaltinis yra nekeičiamas.

## LV:

### Gaismas avots:

Gaismas avotu nevar nomainīt, jo tas konstrukcijā ir cieši savienots ar izstrādājuma apkārtejo daļu.

Šis ražojums satur gaismas avotu, kura energoefektivitātes klase ir <E>.



Vadības ierīci nevar nomainīt.



Apgaismes līdzekli nevar nomainīt.

## NL:

### Lichtbron:

De lichtbron kan niet worden vervangen, omdat deze vanwege de constructie vast met het product eromheen verbonden is.

Dit product bevat een lichtbron van energie-efficiëntieklasse <E>.



Apparaat kan niet worden vervangen.



Verlichting kan niet worden vervangen.

## NO:

### Lyskilde:

Lyskilden kan ikke byttes fordi den sitter fast i produktet.

Dette produktet inneholder en lyskilde i energiklasse <E>.



Driftsapparatet kan ikke byttes ut.



Lyskilden kan ikke byttes ut.

**PL:**Źródło światła:

Źródła światła nie można wymienić, ponieważ jest zintegrowane z produktem ze względu na swoją konstrukcję.

Ten produkt zawiera źródło światła o klasie efektywności energetycznej <E>.



Osprzętu sterującego nie można wymienić.



Źródła światła nie można wymienić.

**PT:**Fonte de Luz:

A fonte de luz não é substituível porque devido às suas características construtivas está fixada de forma permanente ao produto circundante.

Este produto contém uma fonte de luz da classe de eficiência energética <E>.



Dispositivo de comando não substituível.



Lâmpada não substituível.

**RO:**Sursa de lumina:

Sursa de lumina nu este inlocuibilă ea fiind parte constructivă a produsului. Acest produs conține o sursă de lumină cu clasă de eficiență energetică <E>.



Unitatea de control nu poate fi schimbată.



Sursa de lumina nu poate fi schimbată.

**RUS:**Источник света:

Источник света не является взаимозаменяемым, поскольку это определяется конструкцией смежного продукта.

Данный продукт содержит источник света класса энергоэффективности <E>.



Незаменяемый регулировочный механизм.



Незаменяемый источник света.

**SE:**Ljuskälla:

Ljuskällan är inte utbytbar, eftersom den på grund av konstruktionen är fast integrerad i den omgivande produkten.

Denna produkt innehåller en ljuskälla med energieffektivitetsklass <E>.



Driftdonet kan inte bytas ut.



Ljuskällan är inte utbytbar.

**SI:**Izvor svetlobe:

Vir svetlobe ni zamenljiv, ker je določen z zasnovno izdelka v okolici. Ta izdelek vsebuje svetlobni vir razreda energijske učinkovitosti <E>.



Nezamenljiv krmilnik.



Nezamenljiv vir svetlobe.

**SK:**Zdroj svetla:

Svetelný zdroj nie je možné vymeniť, pretože je vďaka svojej konštrukcii pevne spojený s produktom.

Tento výrobok obsahuje svetelný zdroj triedy energetickej účinnosti <E>.



Predradník nie je vymeniteľný.



Svetelný zdroj nie je vymeniteľný.

**SRB:**Izvor svetlosti:

Izvor svetlosti nije zamenljiv, jer je zbog svog dizajna čvrsto povezan sa proizvodom koji ga okružuje.

Ovaj proizvod sadrži izvor svetlosti klase energetske efikasnosti <E>.



Upravljački uređaj nije zamenljiv.



Izvor svetlosti se ne može zameniti.

**TR:**Işık kaynağı:

Konstrüksiyon gereği çevreleyen ürün ile sabit bir şekilde bağlı olduğu için ışık kaynağı değiştirilemez.

Bu ürün, <E> enerji sınıfından bir ışık kaynağına sahiptir.



İşletme cihazı değiştirilemez.



Aydınlatma malzemesi değiştirilemez.

**UK:**Джерело світла:

Джерело світла не можна обміняти, оскільки воно міцно пов'язане з навколишнім виробом завдяки своїй конструкції.

Цей виріб містить джерело світла класу енергоефективності <E>.



Редуктор не є змінним.



Цибулини не взаємозамінні.