

Frequency Bandwidth	Maximal radiation transmitting power
2400-2483.5MHz	<7dBm

- dimmable
- incl.
- RGB colour fixing
- APP
- 2700K-6500K
- RGB colour Change
- sparkle decor
- memory function
- timer
- night light

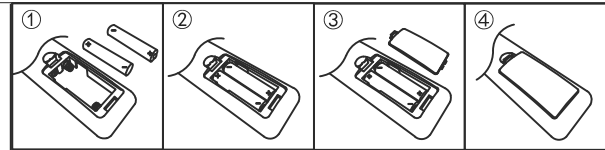

Battery: 2 x AAA 1.5V

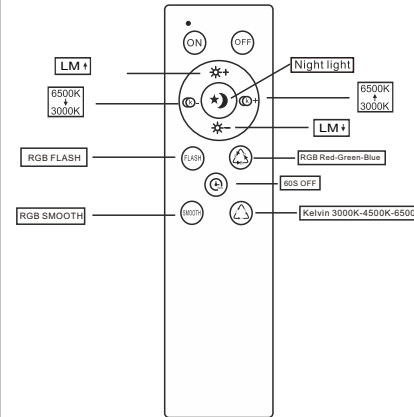

## smart APP control

free APP

compatible with Alexa



compatible with Google Assistant

incl.

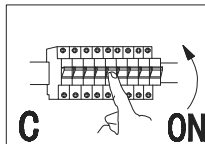
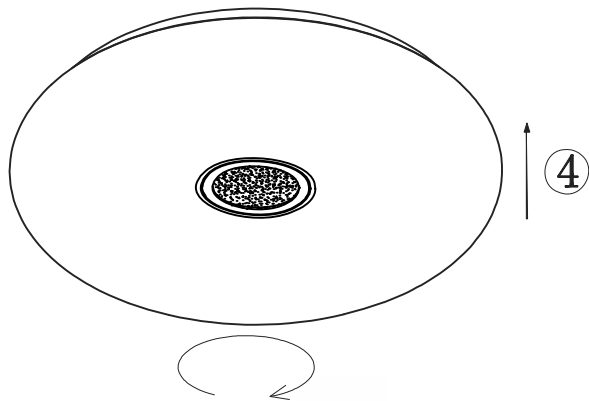
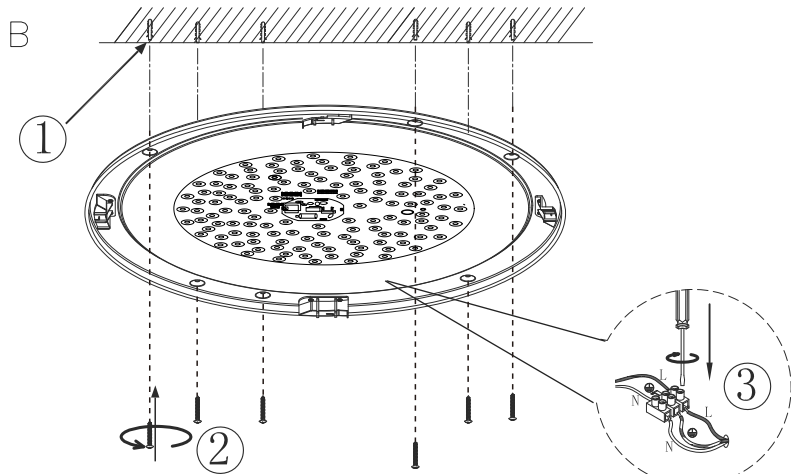

GLOBO Handels GmbH  
Gewerbestr. 3; A-9184 Sankt Peter AUSTRIA

Download Tuya App:



Get latest manual:



Functional Video:



Tuya App - Pairing Process

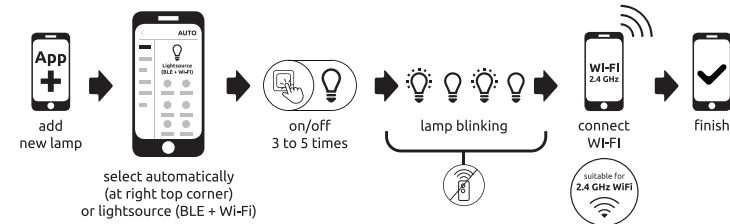

08:00 to 16:00  
(Monday to Friday)

+43 (0)4253 320 50 083

(Please consider, your telephone operator's usual charges for calls to Austria will apply.)

## Lichtquelle /Light Source:

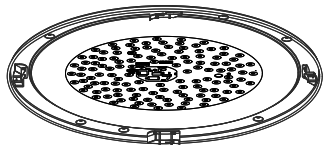

DEU:

### Lichtquelle:

Die Lichtquelle ist nicht tauschbar, weil sie konstruktionsbedingt fest mit dem umgebenden Produkt verbunden ist.

Dieses Produkt enthält eine Lichtquelle der Energieeffizienzklasse <F>.



Leuchtmittel nicht austauschbar.

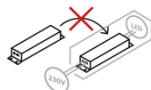

Betriebsgerät nicht austauschbar.

GBR:

### Light source:

The light source is not interchangeable because it is determined by the surrounding product design.

This product contains a light source of energy efficiency class <F>.

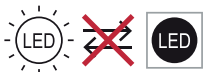

Non replaceable light source.

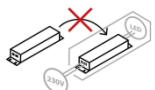

Non replaceable control gear.

BIH.

### Izvor svjetla :

Izvor svjetla nije zamjenjiv , jer je konstrukcijski pričvršćen na proizvod .

Ovaj proizvod sadržava izvor svjetlosti klase energetske učinkovitosti <F>.



LED žarulje nije moguće zamjeniti

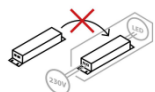

Pogonski uređaj se ne može zamjeniti

BG:

### Източник на светлина:

Източникът на светлина не може да се подменя, тъй като поради конструкцията си е трайно фиксиран към заобикалящия го продукт.

Този продукт включва светлинен източник с клас на енергийна ефективност <F>.



Източникът на светлина не може да се подменя.

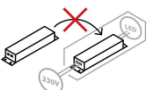

Управляващото устройство не може да се подменя.

CZ:

### Zdroj světla:

Světelný zdroj není možné vyměnit, protože je díky své konstrukci pevně spojený s produktem.

Tento výrobek obsahuje světelný zdroj s třídou energetické účinnosti < F >



Světelný zdroj není vyměnitelný.

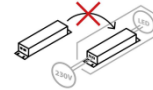

Předřadník není vyměnitelný.

DK:

### Lyskilde:

Lyskilden kan ikke udskiftes, fordi den er fast forbundet med det omgivende produkt.

Dette produkt indeholder en lyskilde i energieffektivitetsklasse <F >.



Lyskilden kan ikke udskiftes.

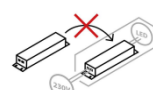

Enheden kan ikke udskiftes.

ET:

### Valgusallikas:

Valgusallikas ei ole välja vahetatav, sest ta on tootega ehituslikult kindlalt seotud.

Toode sisaldab energiatõhususe klassi <F> valgusallikat.



Lamp ei ole välja vahetatav.

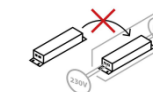

Juhtimiseseadis ei ole välja vahetatav.

FI:

### Valonlähde:

Valonlähdettä ei voi vaihtaa uuteen, sillä se on rakenteellisesti yhdistetty ympäröivään tuotteeseen.

Tämä tuote sisältää valonlähteen, jonka energiatehokkuusluokka on <F>.



Valonlähdettä ei voi vaihtaa.

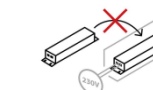

Liitäntälaitetta ei voi vaihtaa.

**FR:**

Source lumineuse:

La source lumineuse n'est pas remplaçable car elle est, de par la construction du produit, liée de façon permanente à celui-ci.

Ce produit contient une source lumineuse de classe d'efficacité énergétique <F>.



Ampoule non remplaçable.

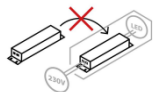

Dispositif de commande non remplaçable.

**GR:**

Φωτεινή πηγή:

Η φωτεινή πηγή δεν μπορεί να αντικατασταθεί, επειδή είναι για κατασκευαστικούς λόγους σταθερά συνδεδεμένη με το προϊόν που την περιβάλλει.

Το προϊόν αυτό περιέχει φωτεινή πηγή της τάξης ενεργειακής απόδοσης <F>.



Ο λαμπτήρας δεν μπορεί να αντικατασταθεί.

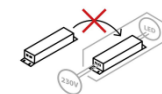

Η διάταξη λειτουργίας δεν μπορεί να αντικατασταθεί.

**HU:**

Fényforrás:

A fényforrás nem cserélhető, mert felépítése miatt szilárdan csatlakozik a termékhez. Ez a termék egy <F> energiahatékonysági osztályú fényforrást tartalmaz.



A fényforrás nem cserélhető

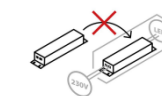

Az előtét nem cserélhető.

**Isländisch/IS:**

Ljósgrjafi:

Ljósgrjafinn er ekki útskiptanlegur vegna þess að hann er háður umliggjandi hönnun vörunnar.

Varan inniheldur ljósgrjafa í orkuflokki < F >.



Ekki útskiptanlegur ljósgrjafi.

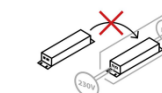

Ekki útskiptanlegur stýribúnaður.

**IT:**

Sorgente luminosa:

La sorgente luminosa non è intercambiabile perché è saldamente collegata al prodotto per via del suo design.

Questo prodotto contiene una sorgente luminosa di classe di efficienza energetica <F>.



Lampadine non intercambiabili.

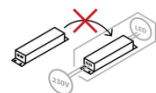

Alimentatore non sostituibile.

**HR:**

Izvor svjetla:

Izvor svjetla nije zamjenjiv, jer je konstrukcijski pričvršćen na proizvod.

Ovaj proizvod sadržava izvor svjetlosti klase energetske učinkovitosti <F>.



LED žarulje nije moguće zamjeniti

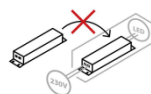

Pogonski uređaj se ne može zamjeniti

**LV:**

Gaismas avots:

Gaismas avotu nevar nomainīt, jo tas konstrukcijā ir cieši savienots ar izstrādājuma apkārtējo daļu.

Šis ražojums satur gaismas avotu, kura energoefektivitātes klase ir <F>.



Apgaismes līdzekli nevar nomainīt.

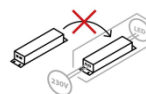

Vadības ierīci nevar nomainīt.

**LT:**

Šviesos šaltinis:

Šis šviesos šaltinis yra nekeičiamas, nes jis prijungtas prie gaminio pagal jo konstrukciją. Šiame gaminyje yra šviesos šaltinis, kurio energijos vartojimo efektyvumo klasė <F>.

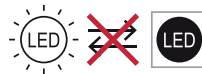

Šviesos šaltinis yra nekeičiamas.

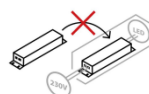

Valdymo įtaisas yra nekeičiamas.

**NL:**  
**Lichtbron:**  
De lichtbron kan niet worden vervangen, omdat deze vanwege de constructie vast met het product eromheen verbonden is.  
Dit product bevat een lichtbron van energie-efficiëntieklasse <F>.



Verlichting kan niet worden vervangen.

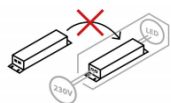

Apparaat kan niet worden vervangen.

**Norwegisch/Norwegian / NO:**

**Lyskilde:**

Lyskilden kan ikke byttes fordi den sitter fast i Produktet.  
Dette produktet inneholder en lyskilde i energiklasse <F>.



Lyskilden kan ikke byttes ut.

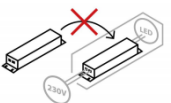

Driftsapparatet kan ikke byttes ut.

**PL:**  
**Źródło światła:**  
Źródła światła nie można wymienić, ponieważ jest zintegrowane z produktem ze względu na swoją konstrukcję.  
Ten produkt zawiera źródło światła o klasie efektywności energetycznej <F>.

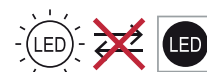

Źródła światła nie można wymienić.

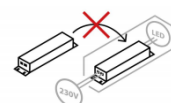

Osprzętu sterującego nie można wymienić.

**PT:**  
**Fonte de Luz:**  
A fonte de luz não é substituível porque devido às suas características construtivas está fixada de forma permanente ao produto circundante.  
Este produto contém uma fonte de luz da classe de eficiência energética <F>.



Lâmpada não substituível.

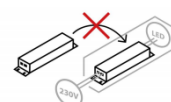

Dispositivo de comando não substituível.

**RO:**  
**Sursa de lumina:**  
Sursa de lumina nu este inlocuibilă ea fiind parte constructivă a produsului.  
Acest produs conține o sursă de lumină cu clasa de eficiență energetică <F>.



Sursa de lumina nu poate fi schimbată

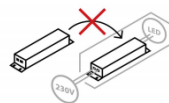

Unitatea de control nu poate fi schimbată

**RUS:**  
**Источник света:**  
Источник света не является взаимозаменяемым, поскольку это определяется конструкцией смежного продукта.  
Данный продукт содержит источник света класса энергоэффективности <F>.



Незаменяемый источник света.

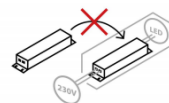

Незаменяемый регулировочный механизм

**SRB:**  
**Izvor svetlosti:**  
Izvor svetlosti nije zamenljiv, jer je zbog svog dizajna čvrsto povezan sa proizvodom koji ga opkružuje.  
Ovaj proizvod sadrži izvor svetlosti klase energetske efikasnosti <F>.



Izvor svetlosti se ne može zameniti.

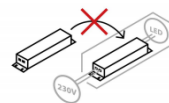

Upravljački uređaj nije zamenljiv.

**SK:**  
**Zdroj svetla:**  
Svetelný zdroj nie je možné vymeniť, pretože je vďaka svojej konštrukcii pevne spojený s produktom.  
Tento výrobok obsahuje svetelný zdroj triedy energetickej účinnosti <F>.

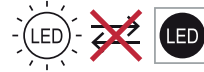

Svetelný zdroj nie je vymeniteľný.

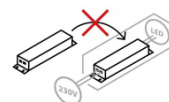

Predradník nie je vymeniteľný.

**SI:**

**Izvor svetlobe:**

Vir svetlobe ni zamenljiv, ker je določen z zasnovo izdelka v okolici.  
Ta izdelek vsebuje svetlobni vir razreda energijske učinkovitosti <F>.



Nezamenljiv vir svetlobe.

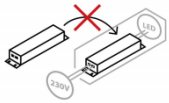

Nezamenljiv krmilnik.

**ES:**

**Fuente de luz:**

La fuente de luz no es sustituible porque está fija en el producto desde la construcción.  
Este producto contiene una fuente luminosa de la clase de eficiencia energética <F>.



Bombilla no reemplazable.

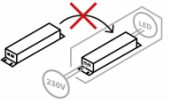

Dispositivo de control no reemplazable.

**SE:**

**Ljuskälla:**

Ljuskällan är inte utbytbar, eftersom den på grund av konstruktionen är fast integrerad i den omgivande produkten.

Denna produkt innehåller en ljuskälla med energieffektivitetsklass <F>.



Ljuskällan är inte utbytbar.

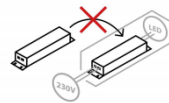

Driftdonet kan inte bytas ut.

**TR:**

**Işık kaynağı:**

Konstrüksiyon gereği çevreleyen ürün ile sabit bir şekilde bağlı olduğu için ışık kaynağı değiştirilemez. Bu ürün, <F> enerji sınıfından bir ışık kaynağına sahiptir.



Aydınlatma malzemesi değiştirilemez.

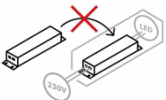

İşletme cihazı değiştirilemez.

**UK:**

**Джерело світла:**

Джерело світла не можна обміняти, оскільки воно міцно пов'язане з навколишнім виробом завдяки своїй конструкції.  
Цей виріб містить джерело світла класу енергоефективності <F>.



Цибулини не взаємозамінні.

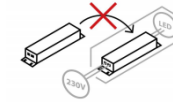

Редуктор не є змінним.